

**SolidWorks Student Edition.  
For Academic Use Only.**

UNLESS OTHERWISE SPECIFIED: DIMENSIONS ARE IN MILLIMETERS SURFACE FINISH: 2.4 TOLERANCES: LINEAR: ±0.50mm ANGULAR: ±1.50°		DEBUR AND BREAK SHARP EDGES WITH 1.5mm CHAMFER WHEREVER NECESSARY		DO NOT SCALE DRAWING		REVISION A	
NAME: Dan Cabral		PART NAME: Overall Dimensions		PART NUMBER: FCP- RS.A			
PROJECT: Free Choice - PDRS		MATERIAL: PP		PROCESS: Injection Moulding		A3	
SUBJECT/UNIT: DPD40004 - PDE6		SCALE: 1:50		SHEET 1 OF 4			

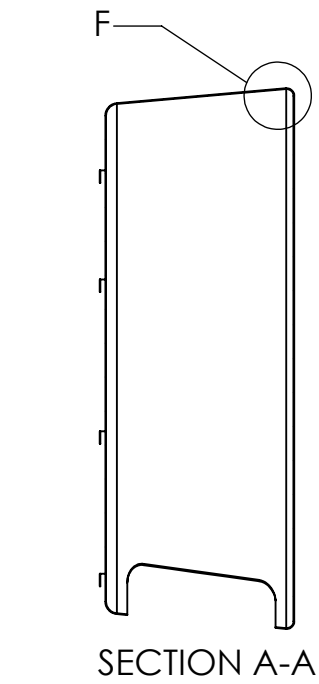

SECTION A-A

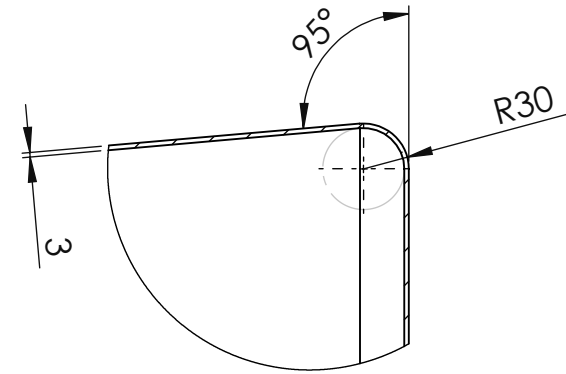

DETAIL F  
SCALE 1 : 5

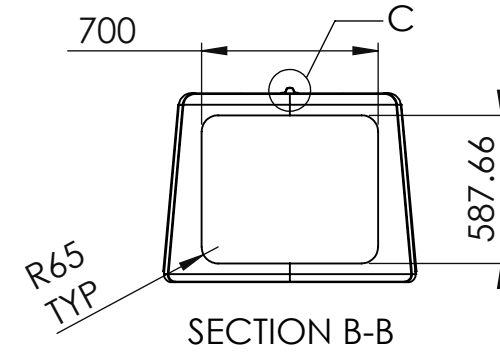
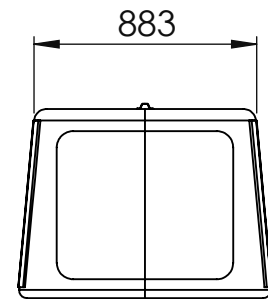
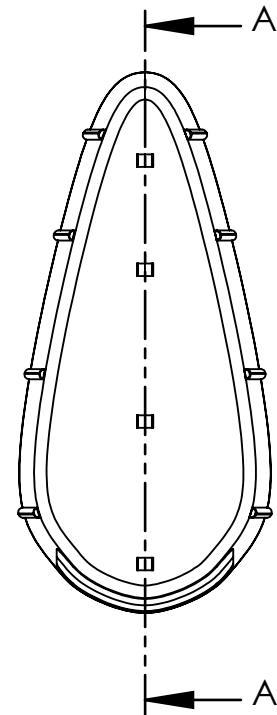

SECTION B-B

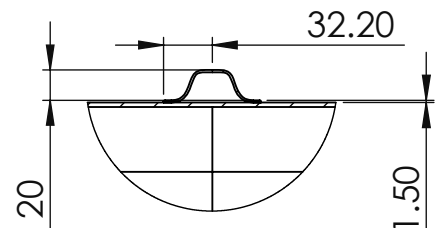
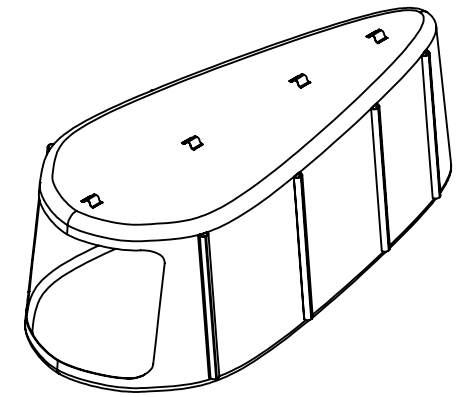

DETAIL C  
SCALE 1 : 5

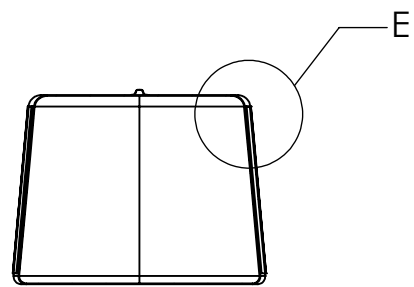
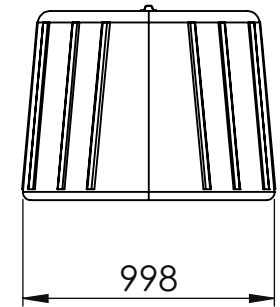
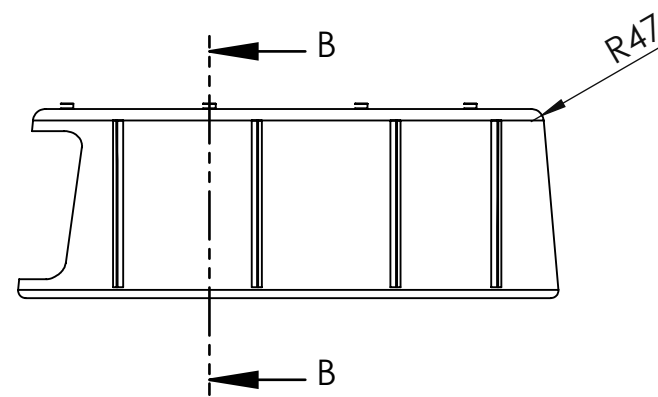
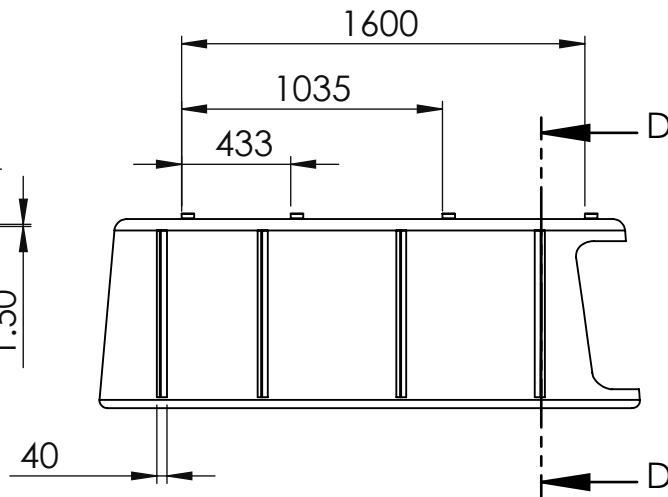

SECTION D-D

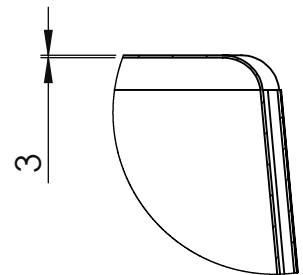

DETAIL E  
SCALE 1 : 10

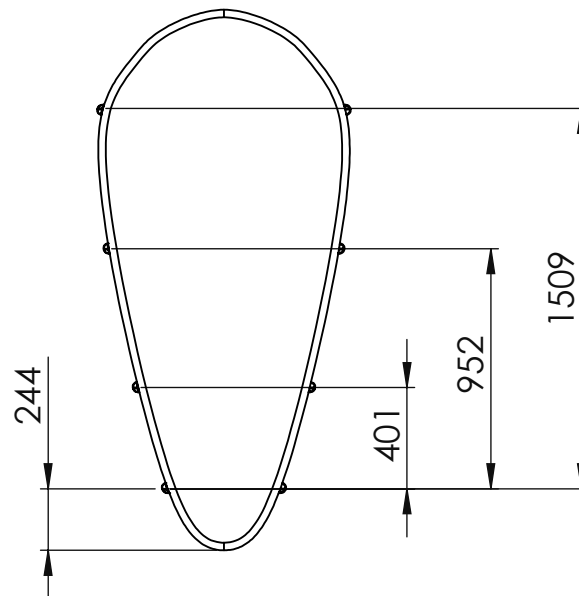

UNLESS OTHERWISE SPECIFIED: DIMENSIONS ARE IN MILLIMETERS SURFACE FINISH: 2.4 TOLERANCES: LINEAR: ±0.50mm ANGULAR: ±1.50°		DEBUR AND BREAK SHARP EDGES WITH 1.5mm CHAMFER WHEREVER NECESSARY		DO NOT SCALE DRAWING		REVISION A	
NAME: Dan Cabral		PART NUMBER: FCP- RS.1		PART NAME: External Cover			
PROJECT: Free Choice - PDRS		MATERIAL: Nylon		PROCESS: Fabricate and Stitch		A3	
SUBJECT/UNIT: DPD40004 - PDE6		SCALE: 1:30		SHEET 2 OF 4			

**SolidWorks Student Edition.  
For Academic Use Only.**

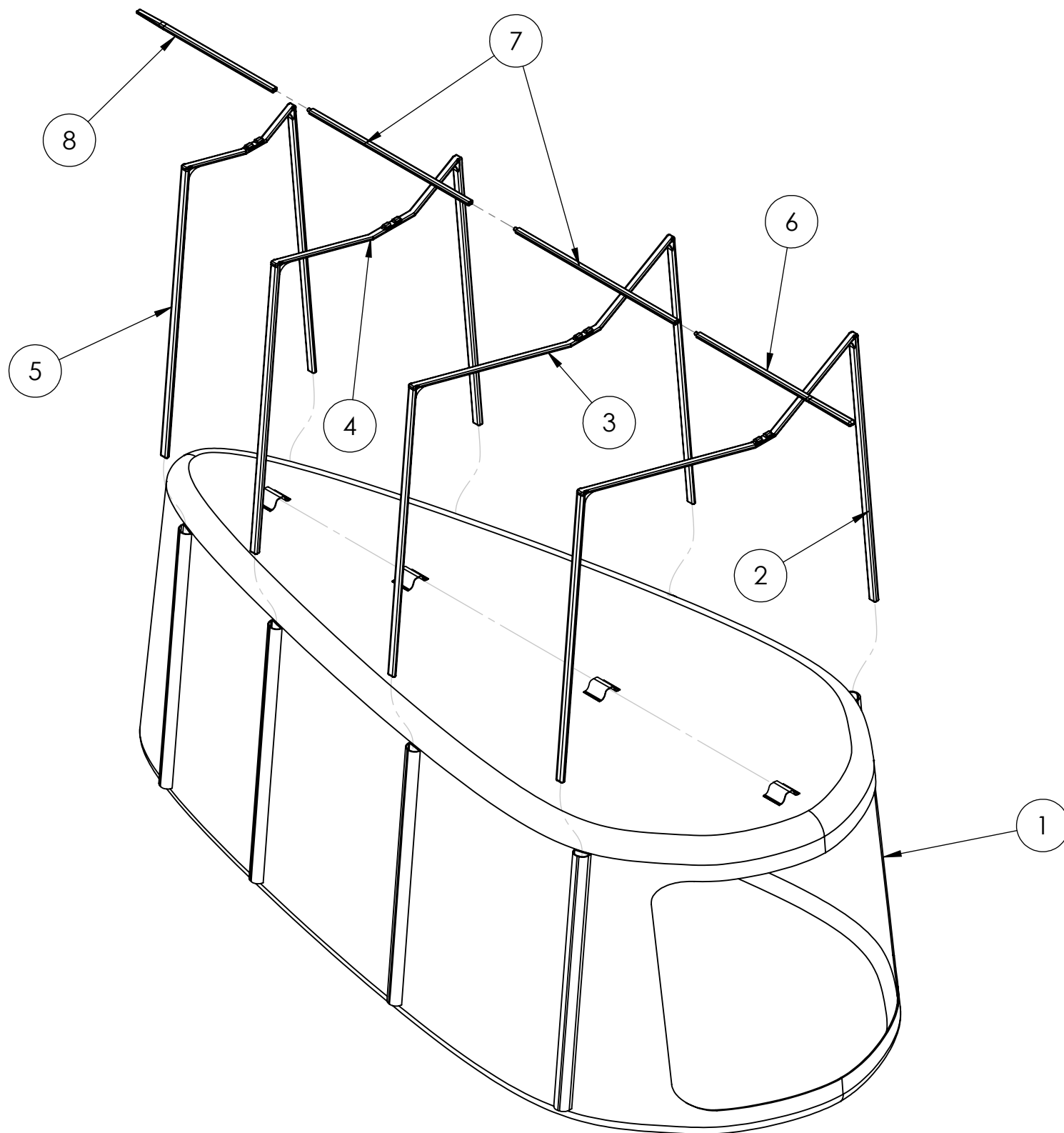

ITEM NO.	PART NUMBER	DESCRIPTION	MATERIAL	PROCESS	QTY.
1	FCP-RS.1	External Cover	Nylon	Fabrication and Stitching	1
2	FCP-RS.2	Structural Spline 1	HDPE	Injection Moulding	1
3	FCP-RS.3	Structural Spline 2	HDPE	Injection Moulding	1
4	FCP-RS.4	Structural Spline 3	HDPE	Injection Moulding	1
5	FCP-RS.5	Structural Spline 4	HDPE	Injection Moulding	1
6	FCP-RS.6	Connecting Member 1	HDPE	Injection Moulding	1
7	FCP-RS.7	Connecting Member 2	HDPE	Injection Moulding	2
8	FCP-RS.8	Connecting Member 3	HDPE	Injection Moulding	1

**SolidWorks Student Edition.  
For Academic Use Only.**

UNLESS OTHERWISE SPECIFIED: DIMENSIONS ARE IN MILLIMETERS SURFACE FINISH: 2.4 TOLERANCES: LINEAR: ±0.50mm ANGULAR: ±1.50°		DEBUR AND BREAK SHARP EDGES WITH 1.5mm CHAMFER WHEREVER NECESSARY		DO NOT SCALE DRAWING		REVISION A	
NAME: Dan Cabral				PART NUMBER: <b>FCP- RS.A</b>			
PROJECT: Free Choice - PDRS				PART NAME: <b>Exploded View</b>			
SUBJECT/UNIT: DPD40004 - PDE6		MATERIAL: Nylon		PROCESS: Fabricate and Stitch		A3	
				SCALE: 1:12		SHEET 3 OF 4	

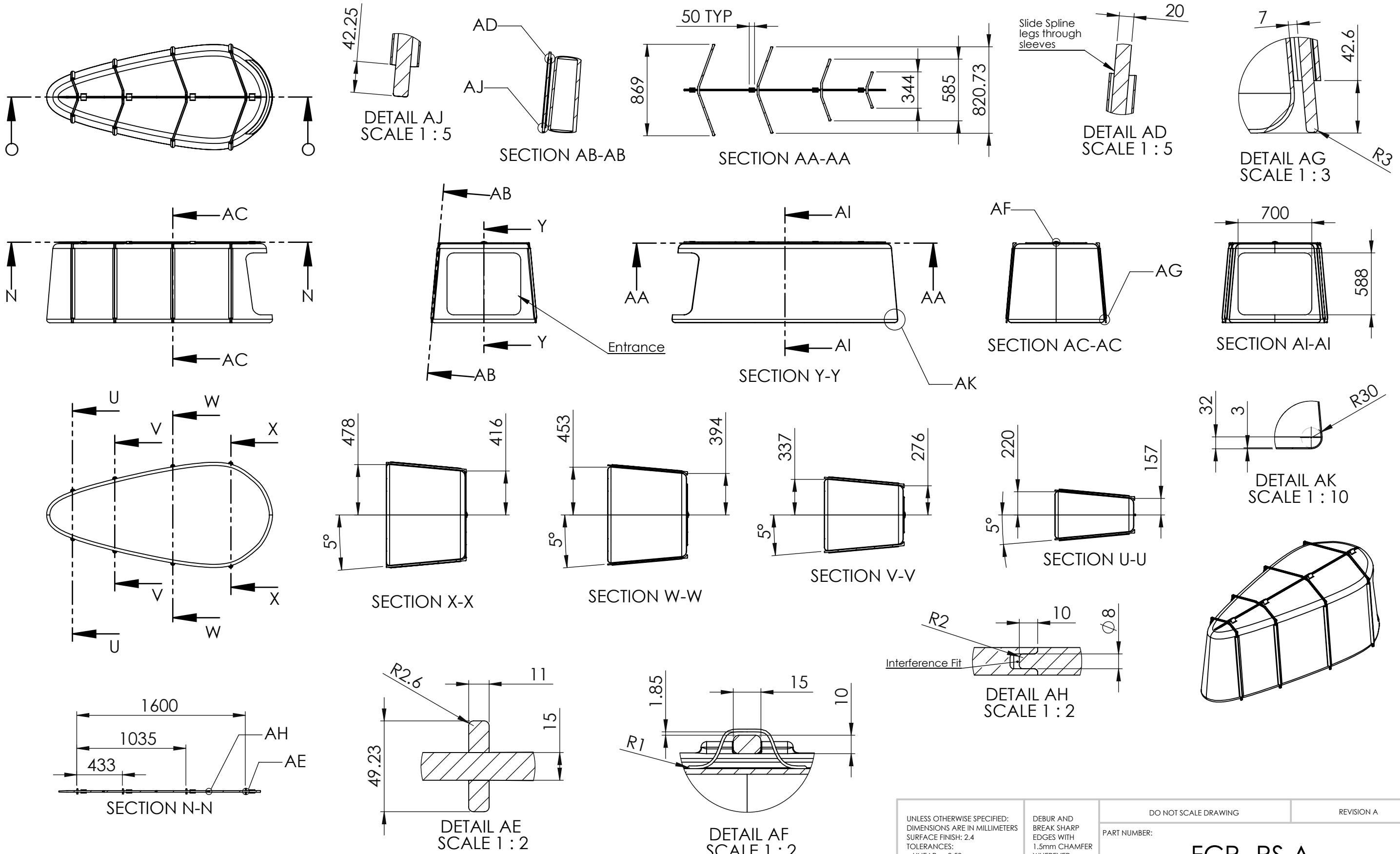

**SolidWorks Student Edition.  
For Academic Use Only.**

UNLESS OTHERWISE SPECIFIED: DIMENSIONS ARE IN MILLIMETERS SURFACE FINISH: 2.4 TOLERANCES: LINEAR: ±0.50mm ANGULAR: ±1.50°		DEBUR AND BREAK SHARP EDGES WITH 1.5mm CHAMFER WHEREVER NECESSARY		DO NOT SCALE DRAWING		REVISION A	
NAME: Dan Cabral				PART NUMBER: <b>FCP- RS.A</b>			
PROJECT: Free Choice - PDRS				PART NAME: Assembly Detail			
SUBJECT/UNIT: DPD40004 - PDE6		MATERIAL: Nylon		PROCESS: Fabricate and Stitch		A3	
				SCALE: 1:35		SHEET 4 OF 4	